

NON-ROTATING SPINDLE

BLADE MICROMETERS

- Meet DIN863-3
- Measure the groove diameter of shafts and keyways
- Graduation 0.01mm
- Non-rotating spindle
- Ratchet stop
- Supplied with setting standards (except 0-25mm)



3232-25A

Code	Range	Type	Accuracy	L	b
3232-25A	0-25mm	A	4µm	57	32
3232-50A	25-50mm	A	4µm	82	44.5
3232-75A	50-75mm	A	5µm	107	57
3232-100A	75-100mm	A	5µm	132.6	69.5
3232-125A	100-125mm	A	6µm	158	82
3232-150A	125-150mm	A	6µm	183.4	94.5
3232-175A	150-175mm	A	7µm	208.8	107
3232-25BA	0-25mm	B	4µm	57	32
3232-50BA	25-50mm	B	4µm	82	44.5
3232-75BA	50-75mm	B	5µm	107	57
3232-100BA	75-100mm	B	5µm	132.6	69.5
3232-125BA	100-125mm	B	6µm	158	82
3232-150BA	125-150mm	B	6µm	183.4	94.5
3232-175BA	150-175mm	B	7µm	208.8	107

(mm)

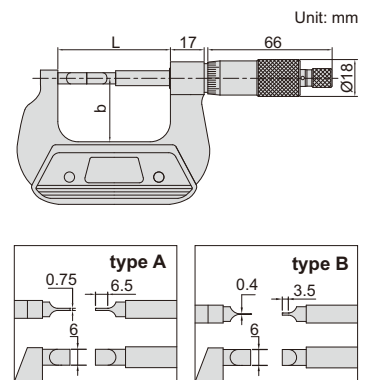

DATA OUTPUT

NON-ROTATING SPINDLE

DIGITAL BLADE MICROMETERS

- Measure the groove diameter of shafts and keyways
- Resolution 0.001mm/0.00005"
- Non-rotating spindle
- Button function: on/off, set, mm/inch, ABS/INC
- Data output
- Automatic power off
- Ratchet stop
- Supplied with setting standards (except 0-25mm/0-1")
- Optional accessory: data output cable (code 7315-30, 7302-30)



3532-25A

Code	Range	Type	Accuracy	L	b
3532-25A	0-25mm/0-1"	A	±4µm	57	32
3532-50A	25-50mm/1-2"	A	±4µm	82	44.5
3532-75A	50-75mm/2-3"	A	±5µm	107	57
3532-100A	75-100mm/3-4"	A	±5µm	132.6	69.5
3532-125A	100-125mm/4-5"	A	±6µm	158	82
3532-150A	125-150mm/5-6"	A	±6µm	183.4	94.5
3532-175A	150-175mm/6-7"	A	±7µm	208.8	107
3532-25BA	0-25mm/0-1"	B	±4µm	57	32
3532-50BA	25-50mm/1-2"	B	±4µm	82	44.5
3532-75BA	50-75mm/2-3"	B	±5µm	107	57
3532-100BA	75-100mm/3-4"	B	±5µm	132.6	69.5
3532-125BA	100-125mm/4-5"	B	±6µm	158	82
3532-150BA	125-150mm/5-6"	B	±6µm	183.4	94.5
3532-175BA	150-175mm/6-7"	B	±7µm	208.8	107

(mm)

